

Specification MAM Series



Key Features

- Form, fit and function replacement for MG 500 watt range
- 90-132VAC or 180-264VAC operation
- Connections as original MG range
- Complete transparency to end user

Specifications

Input specification

Input voltage Range	90-132VAC or 180-264VAC
Frequency	47 to 63Hz.
Inrush current	30A AC max.
Operating Current	8.6A AC max.
Efficiency	Typically 82% at full load.
Power factor	0.70 typical. Meets EN61000-3-2.
EMI-filter standard	CISPR 22, EN55022 "A".
Radiated EMI	CISPR 22, EN55022 "A".
Holdup time	28ms min (at 500W load).
Harmonic Distortion	Meets EN61000-3-2.
Isolation	Meets EN60950.

Output specification

Overall regulation	Less than 0.2% (24/28V). Less than 0.1% (48V)
Ripple pk-pk (20MHz bandwidth)	50mV max.
Current limit	105-125% of rated output current
Protection	Protected for continuous short circuit
Overvoltage protection	110-125% of nominal output (recycle AC input to reset).
Thermal protection	All outputs disabled when internal temp exceeds safe operating range.
Remote sense	Remote sense available. Local sense links fitted as standard.
Minimum load	Not required
Indicators	Output ON LED

General

Cooling	Convection
Operating temperature	-10°C to 70°C. For 50°C to 70°C, de-rate output by 2.5% per °C
Weight	4.0kg unpacked

Specification

MAM Series

Mechanical Outline

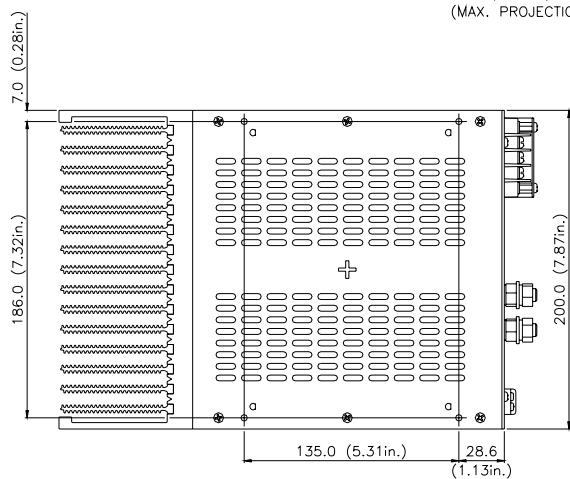
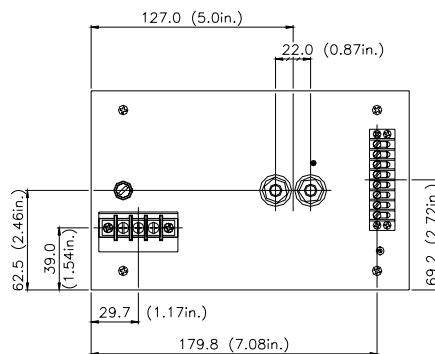
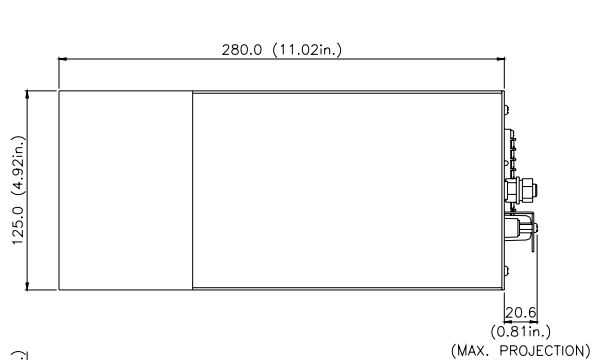

α - 4 x M4 FIXINGS

